

DIŐA TAKILAN PANJUR PROFİLLERİ

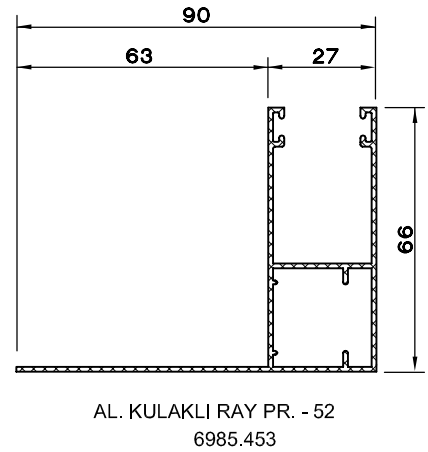
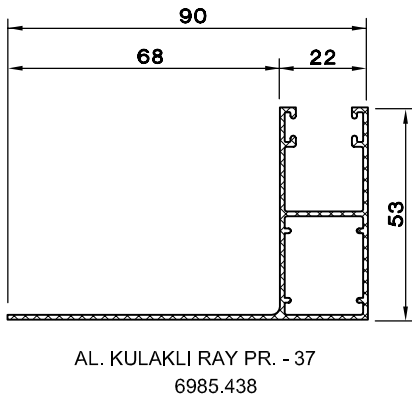
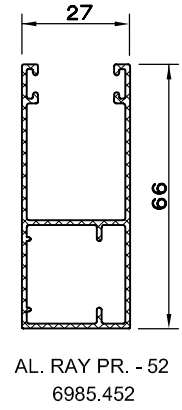
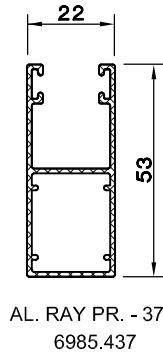
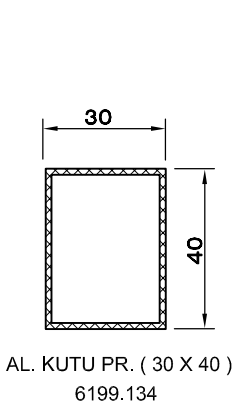
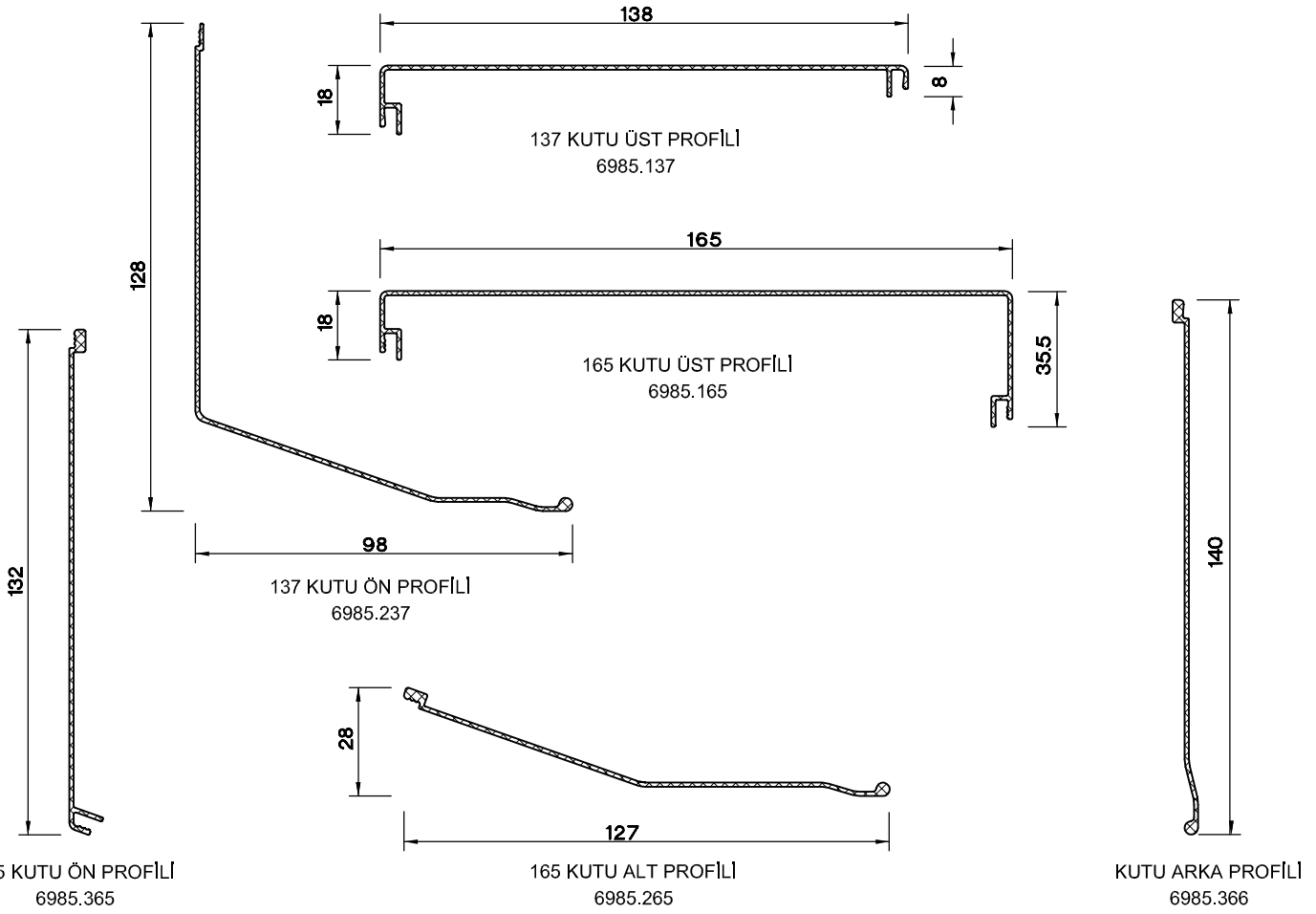

DIŐTAN TAKMALI PANJUR DOĐRAMA PRENSİPLERİ

PİMAPEN

S-6000 QUADRO

- * DOĐRAMAYA MONTAJLI (AÇILIR PANJUR, SABİT PANJUR, MOTORLU PANJUR)
- * DUVARA MONTAJLI (AÇILIR PANJUR, SABİT PANJUR, MOTORLU PANJUR)

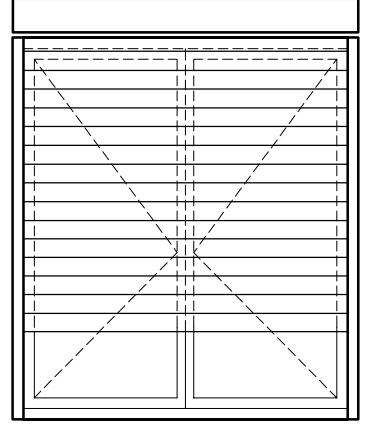
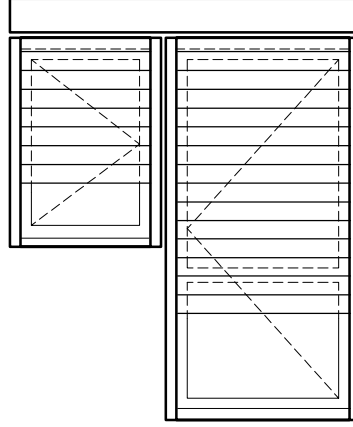
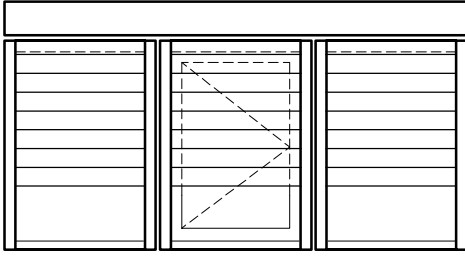

DIŐTAN TAKMALI
PANJUR KUTU PR. SETİ (165)

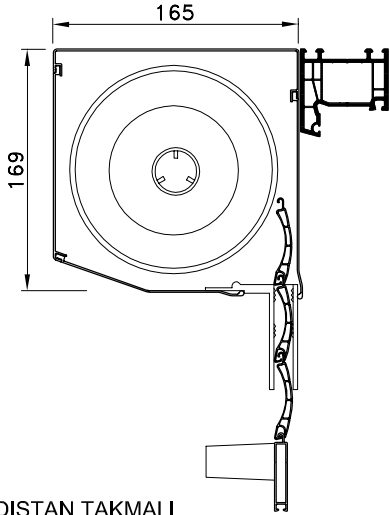

DIŐTAN TAKMALI
PANJUR KUTU PR. SETİ (137)

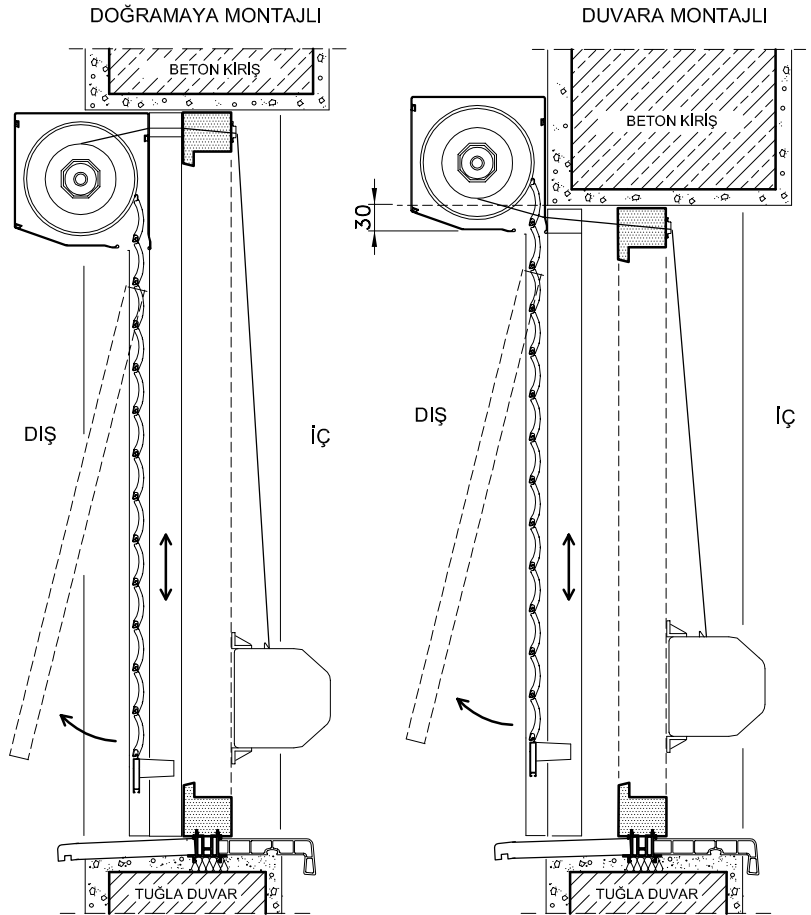
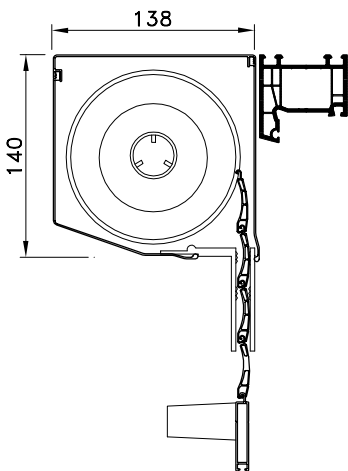

| PANJUR | | | |
|---------------|-----------------|---------------------------|---------------------------|
| LAMEL TİPİ | GENİŐLİK MAX | KUTU 137 YÜKSEKLİK MAX | KUTU 165 YÜKSEKLİK MAX |
| 37mm | 140cm | 175cm | 250cm |
| 52mm | 190cm | - | 150cm |

DOĐRAMAYA MONTAJLI

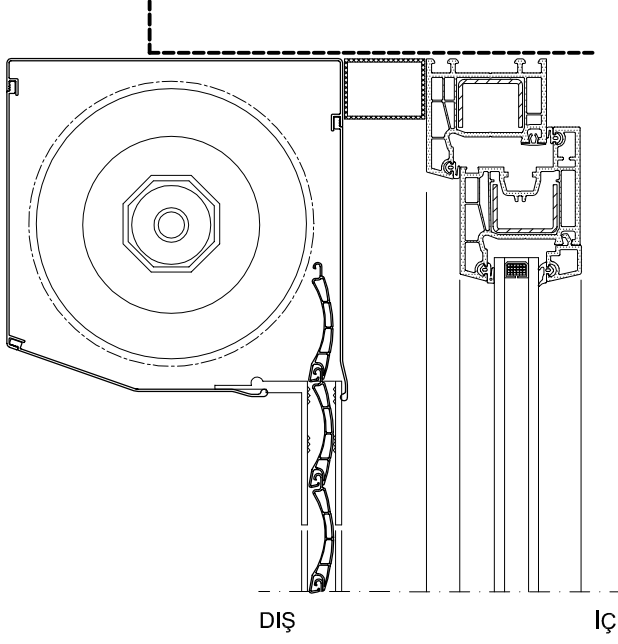

DUVARA MONTAJLI

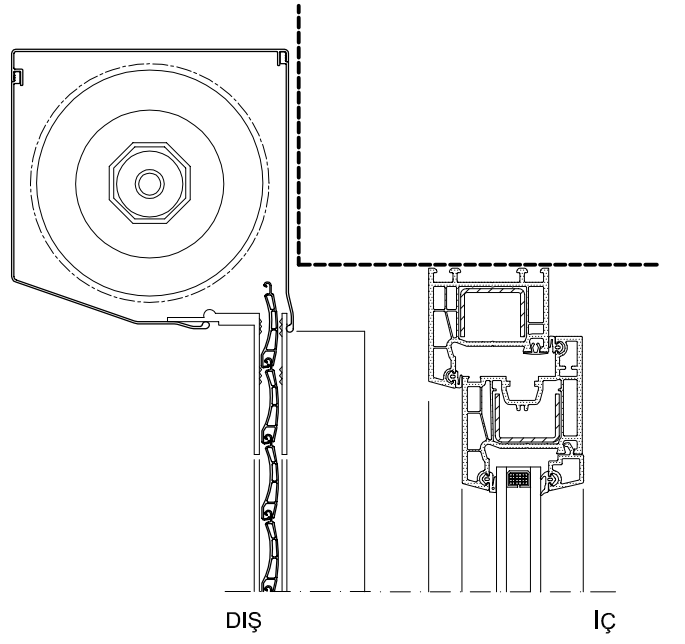

DIŐ IÇ

DIŐ IÇ

KESİT

KESİT

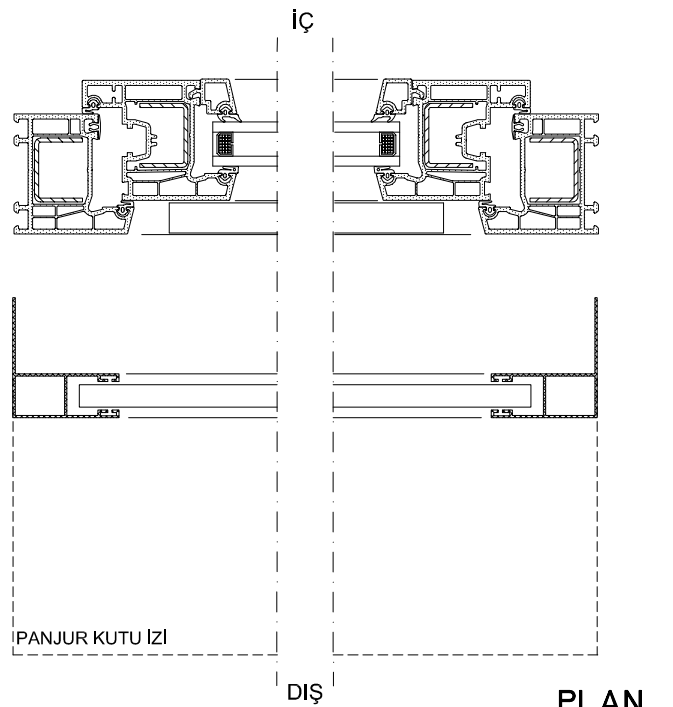
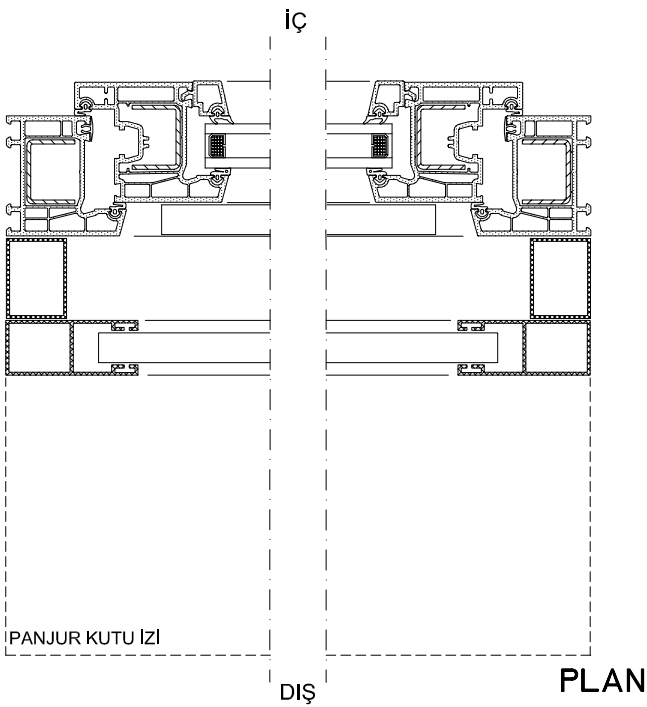

KİLİTLİ KAPI İÇİN DIŞA TAKILAN PANJUR MONTAJ DETAYI

PIMAPEN
S-6000 *QUADRO*

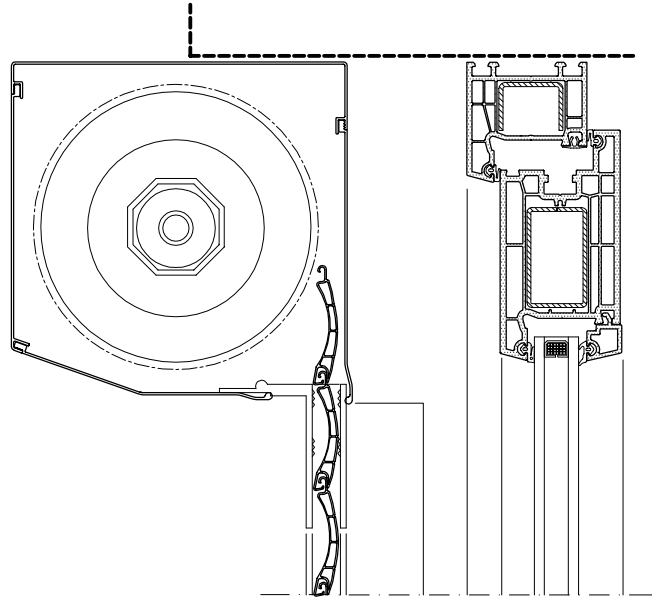

DIŞ

İÇ



KESİT

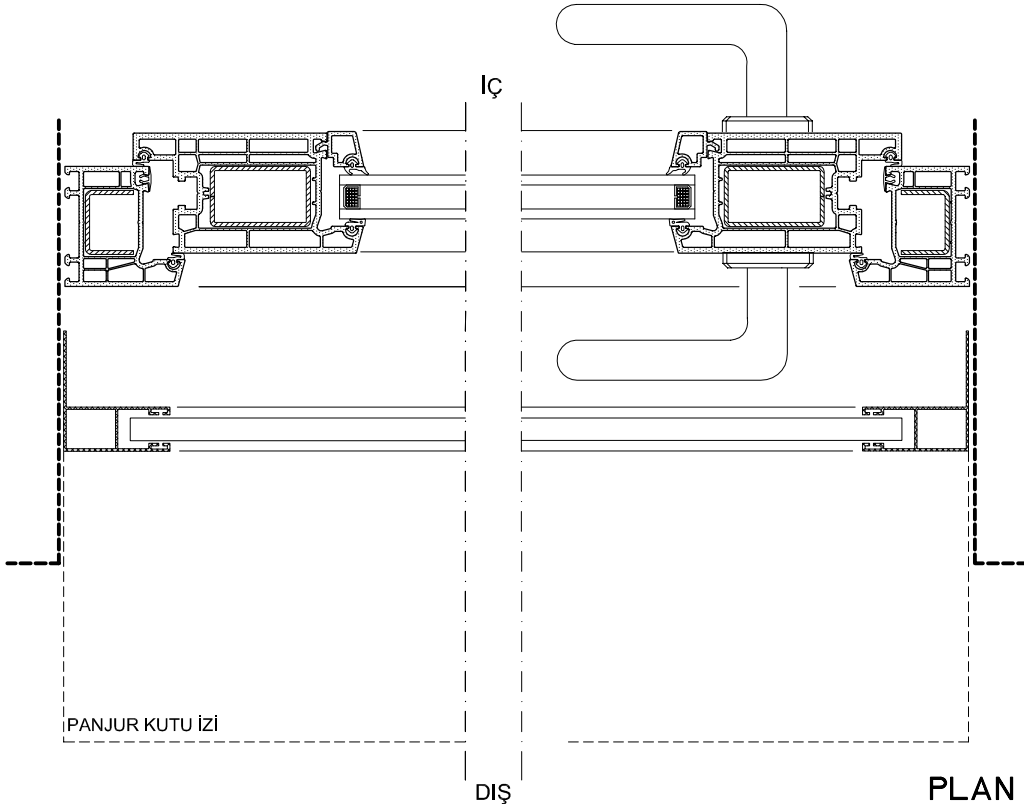

PANJUR KUTU İZİ

DIŞ

PLAN

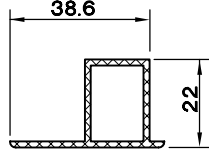

AL. RAY ALT PR.
6980.501

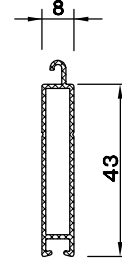

AL. BİTİM LAMELİ PR.
6980.505

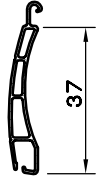

LAMEL PR. - 37
1980.637



DESTEK LAMEL PR. - 37
1980.638

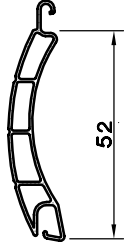

LAMEL PR. - 52
1980.652

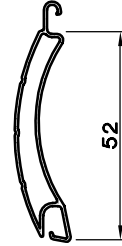

DESTEK LAMEL PR. - 52
1980.653

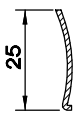

LAMEL - 37 DESTEK SACI
5980.210

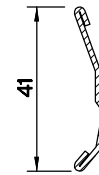

LAMEL - 52 DESTEK SACI
5980.220